

AMERICAN SUPERABRASIVES CORP.

59 Avenue at the Common Shrewsbury , NJ 07702

email-njabrasive@aol.com www.diamond-abrasives.com

TEL-732.389.8066 FAX 732.389.8069

SB60

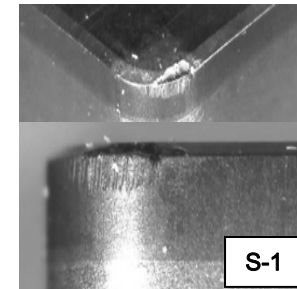
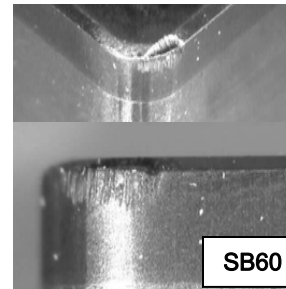
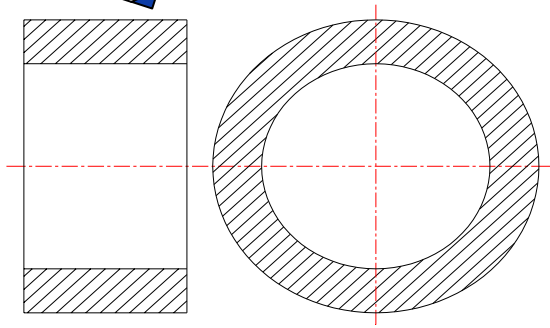

Grade	IBON-SB60
Operation	Continuous Turning
Work material	SKD11 (HRC58-60)
Machining Parameter	Cutting speed = 100 m/min Depth of cut = 0.25 mm Feed rate = 0.1 mm/rev Coolant : Dry
Insert type	SNGN120408
Holder type	CSDNN2525-M12C

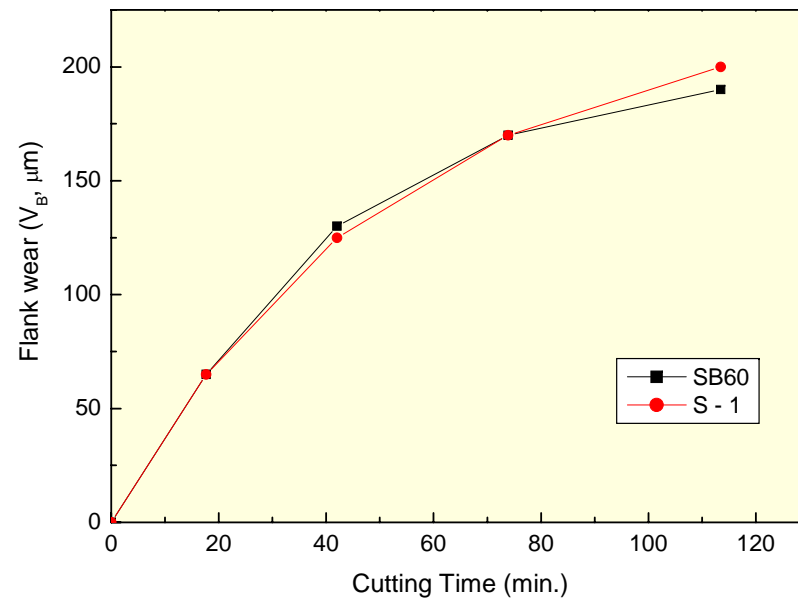

Confidential Information

The Best Technology of Materials



Diamond