

AMERICAN SUPERABRASIVES CORP.

59 Avenue at the Common Shrewsbury , NJ 07702

email-njabrasive@aol.com www.diamond-abrasives.com

TEL-732.389.8066 FAX 732.389.8069

SB90

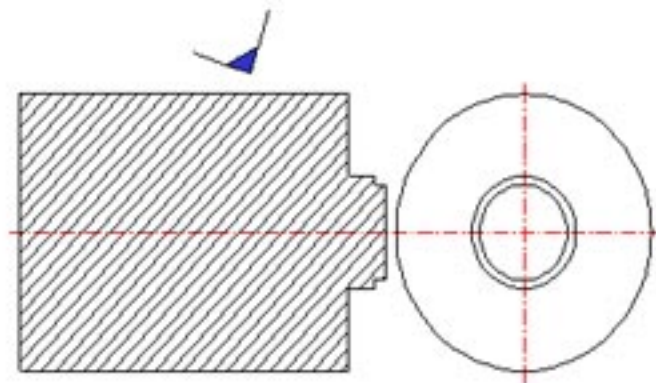

Grade	IBON-SB90
Operation	Continuous Turning
Work material	Hard Cast Iron
Machining Parameter	Cutting speed = 500 m/min Depth of cut = 0.5 mm Feed rate = 0.25 mm/rev Coolant : Dry
Insert type	SNGN120408
Holder type	CSDNR2525-M12C

