

SB80

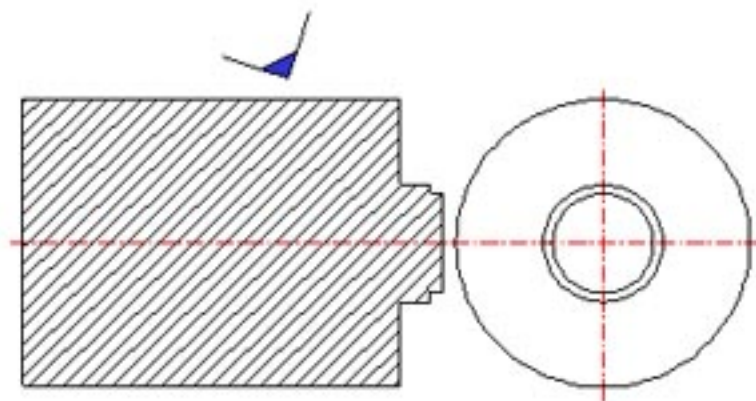

Grade	IBON-SB80
Operation	Continuous Turning
Work material	Inconel718
Machining Parameter	Cutting speed = 130 m/min Depth of cut = 0.5 mm Feed rate = 0.12 mm/rev Coolant : wet
Insert type	SNGN120408
Holder type	CSDNR2525-M12C

